

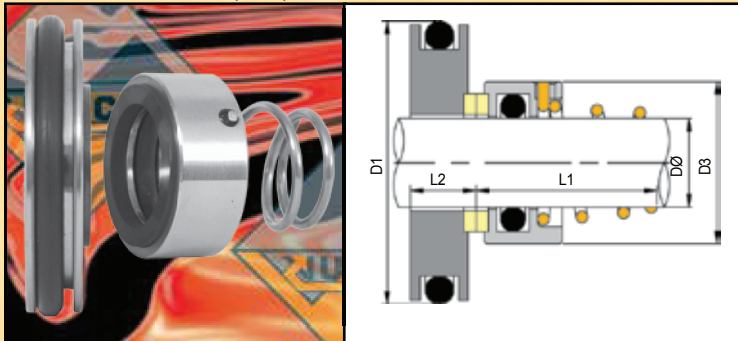

VULCAN® SEALS FOR ALLWEILER® PUMPS

Vulcan manufacture and stock a wide range of seals to suit Allweiler® pumps, including many standard range seals, such as the Type 8DIN and 8DINS, Type 24 and Type 1677M seals. The following are examples of specific dimensions seals designed to suit the internal dimensions of certain Allweiler® pumps only.

TYPE 8W TO SUIT BAS, SPF, ZAS AND ZASV SERIES PUMPS V H D 304



'O'-Ring mounted conical spring seals with distinctive stationaries, to suit the seal chambers of "BAS, SPF, ZAS and ZASV" series spindle or screw pumps, commonly found in ship's engine rooms on oil and fuel duties. Clockwise rotation springs are standard.

SHAFT SIZE DØ	SIZE CODE	D1	D3	L1	L2
15.00	0150	38.00	24.00	15.00	8.00
20.00	0200	45.00	31.00	19.50	8.50

TYPE 8X TO SUIT SOB AND SOH SERIES PUMPS V D 304

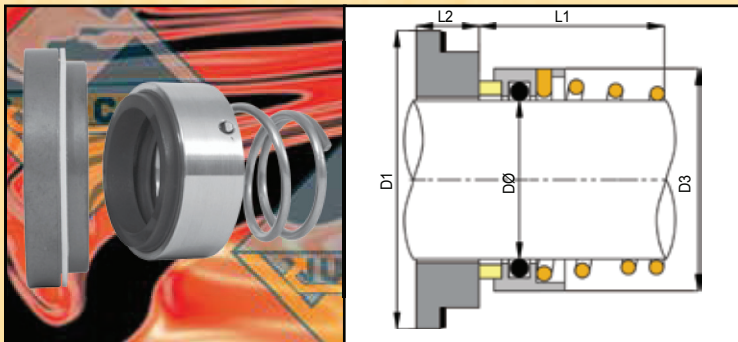

'O'-Ring mounted conical spring 22mm seals with distinctive gasket mounted seat rings, to suit "SOB" and "SOH" series pumps, commonly found in ship's engine rooms. Clockwise rotation springs are standard.

SHAFT SIZE DØ	SIZE CODE	D1	D3	L1	L2
22.00*	0220	44.00	33.00	21.50	11.25

TYPE 82A TO SUIT L- AND LV- SERIES PUMPS E D 304

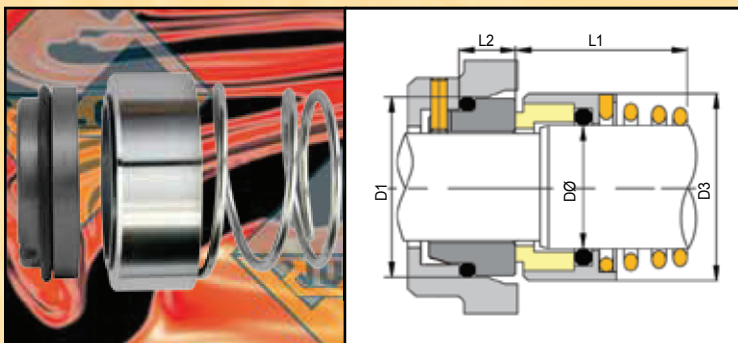

'O'-Ring mounted conical spring, stepped shaft, balanced seals with 'O'-Ring mounted stationaries, to suit specific dimensions of commonly marine-application "L and LV" series pumps. "LV" pumps have vertical shafts and only require one clockwise rotation seal, but "L" series are horizontal, double-ended pumps and require one clockwise and one anti-clockwise seal per pump.

Many Allweiler pumps accept Vulcan standard range seals, such as types 8DIN and 8DINS. Some of the seals, are detailed here or in earlier sections of the catalogue, if you can not find what you require, please contact us with the O.E.M. details for cross-reference on our database.

SHAFT SIZE DØ	SIZE CODE	D1	D3	L1	L2
28.00*	0330	43.00	46.00	39.50	8.5
30.00*	0350	45.00	49.00	39.50	9.0
45.00*	0500	63.00	66.00	55.00	9.0

VULCAN® TYPE 198 SEALS TO SUIT ANDRITZ® PUMPS EV AS SS 304

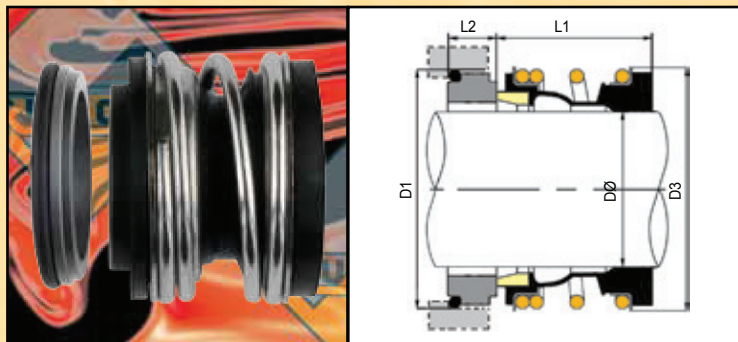

'O'-Ring mounted rubber bellows seals to DIN24960 / EN12756 dimensions, but with a balanced rotary face profile and special stationary profiles, to suit service in Andritz® "S"-series centrifugal pumps, commonly found in paper and cellulose processing.

SHAFT SIZE DØ	SIZE CODE	D1	D3	L1	L2
38.00	0380	56.00	57.30	36.00	9.00
48.00	0480	66.00	69.00	36.00	9.00
53.00	0530	73.00	76.00	36.50	11.00
65.00*	0650	85.00	90.00	41.50	11.00
90.00*	0900	115.00	126.00	51.00	14.00

Advice on our Material Codes shown above and our standard coding system are on Pages 91 & 18 of this brochure. For ease, please refer to our O.E.M. Price List where you will find a clear list, filterable by either the O.E.M.'s name or Vulcan Seal Type number, showing all common materials and stock codes, pricing and Stock Guarantee.

All seals / sizes / materials detailed above are guaranteed ex-stock, unless asterisked. For any other sizes, or identification by X-reference, please refer to the on-line O.E.M. database, or contact us with your requirements.