

# Standard Sprockets for 3/8" Pitch British Standard Chains Type 06B

Conforming to ISO Std 606

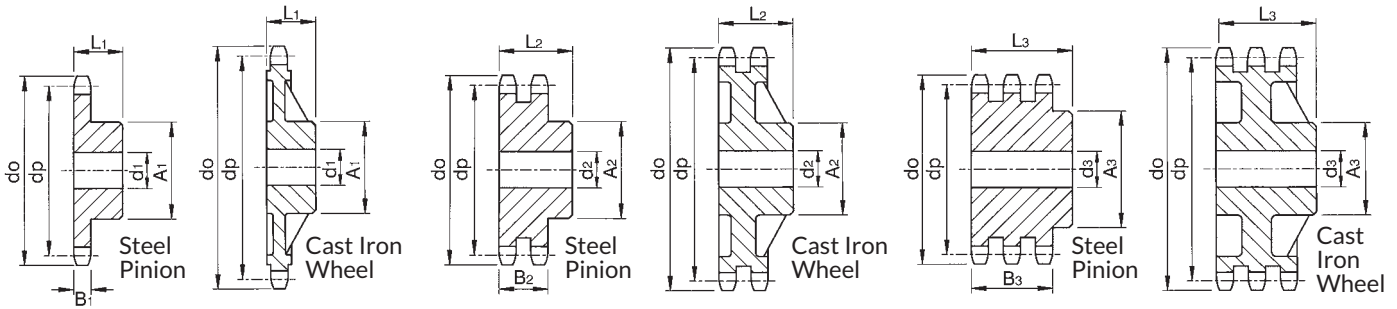

## Simplex Sprockets Chain No. 06B-1

Pitch 9.525mm  
Roller Dia. 6.35mm  
Inside Width 5.72mm  
Overall Width 15.0mm  
Tooth Width B<sub>1</sub> 5.3mm

## Duplex Sprockets Chain No. 06B-2

Pitch 9.525mm  
Roller Dia. 6.35mm  
Inside Width 5.72mm  
Overall Width 25.1mm  
Tooth Width B<sub>2</sub> 15.4mm

## Triplex Sprockets Chain No. 06B-3

Pitch 9.525mm  
Roller Dia. 6.35mm  
Inside Width 5.72mm  
Overall Width 35.0mm  
Tooth Width B<sub>3</sub> 25.6mm

No. Teeth Z	Pitch Circle Ø dp	Outside Ø do	Simplex Sprocket						Duplex Sprocket						Triplex Sprocket					
			Cat. No.	Min. † Bore d <sub>1</sub>	Max. Bore d <sub>1</sub>	L.T.B. L <sub>1</sub>	Hub Ø A <sub>1</sub>	App. Weight kg	Cat. No.	Min. † Bore d <sub>2</sub>	Max. Bore d <sub>2</sub>	L.T.B. L <sub>2</sub>	Hub Ø A <sub>2</sub>	App. Weight kg	Cat. No.	Min. † Bore d <sub>3</sub>	Max. Bore d <sub>3</sub>	L.T.B. L <sub>3</sub>	Hub Ø A <sub>3</sub>	App. Weight kg
<b>Steel Pinions</b>																				
8	24.89	28.0	06B1-08	8	10	22	15	0.03	06B2-08	6	10	22	15	0.03	06B3-08	6	10	32	15	0.05
9	27.85	31.0	06B1-09	8	12	22	18	0.04	06B2-09	8	12	22	18	0.05	06B3-09	8	12	32	18	0.07
10	30.82	34.0	06B1-10	8	13	22	20	0.05	06B2-10	8	13	22	20	0.06	06B3-10	10	13	32	20	0.08
11	33.80	37.0	06B1-11	8	14	25	22	0.08	06B2-11	10	14	25	22	0.08	06B3-11	10	14	35	22	0.12
12	36.80	40.0	06B1-12	8	16	25	25	0.10	06B2-12	10	16	25	25	0.11	06B3-12	10	16	35	25	0.15
13	39.80	43.0	06B1-13	10	19	25	28	0.12	06B2-13	10	19	25	28	0.13	06B3-13	10	19	35	28	0.19
14	42.81	46.3	06B1-14	10	20	25	31	0.15	06B2-14	10	20	25	31	0.17	06B3-14	12	20	35	31	0.23
15	45.81	49.3	06B1-15	10	23	25	34	0.18	06B2-15	10	23	25	34	0.20	06B3-15	12	23	35	34	0.27
16	48.83	52.3	06B1-16	10	25	28	37	0.24	06B2-16	12	25	30	37	0.27	06B3-16	12	25	35	37	0.32
17	51.83	55.3	06B1-17	10	27	28	40	0.28	06B2-17	12	27	30	40	0.31	06B3-17	12	27	35	40	0.38
18	54.85	58.3	06B1-18	10	29	28	43	0.32	06B2-18	12	29	30	43	0.36	06B3-18	12	29	35	43	0.44
19	57.87	61.3	06B1-19	10	30	28	45	0.36	06B2-19	12	31	30	46	0.41	06B3-19	12	31	35	46	0.50
20	60.89	64.3	06B1-20	10	31	28	46	0.38	06B2-20	12	33	30	49	0.47	06B3-20	12	33	35	49	0.56
21	63.91	68.0	06B1-21	12	32	28	48	0.42	06B2-21	12	35	30	52	0.53	06B3-21	14	35	40	52	0.71
22	66.93	71.0	06B1-22	12	34	28	50	0.45	06B2-22	12	37	30	55	0.60	06B3-22	14	37	40	55	0.79
23	69.95	73.5	06B1-23	12	35	28	52	0.49	06B2-23	12	38	30	58	0.66	06B3-23	14	38	40	58	0.88
24	72.97	77.0	06B1-24	12	36	28	54	0.54	06B2-24	12	41	30	61	0.73	06B3-24	14	41	40	61	0.98
25	76.00	80.0	06B1-25	12	38	28	57	0.60	06B2-25	12	43	30	64	0.81	06B3-25	14	43	40	64	1.07
26	79.02	83.0	06B1-26	12	40	28	60	0.66	06B2-26	12	45	30	67	0.88	06B3-26	14	45	40	67	1.18
27	82.05	86.0	06B1-27	12	40	28	60	0.68	06B2-27	12	47	30	70	0.96	06B3-27	14	47	40	70	1.28
28	85.07	89.0	06B1-28	12	40	28	60	0.69	06B2-28	12	49	30	73	1.04	06B3-28	14	49	40	73	1.39
29	88.10	92.0	06B1-29	12	40	28	60	0.71	06B2-29	12	51	30	76	1.13	06B3-29	14	51	40	76	1.51
30	91.13	94.7	06B1-30	12	40	30	60	0.77	06B2-30	12	53	30	79	1.22	06B3-30	14	53	40	79	1.62
31	94.16	98.3	06B1-31	14	43	30	65	0.87	06B2-31	16	54	30	80	1.27	06B3-31	16	54	40	80	1.72
32	97.17	101.3	06B1-32	14	43	30	65	0.89	06B2-32	16	54	30	80	1.32	06B3-32	16	54	40	80	1.80
33	100.20	104.3	06B1-33	14	43	30	65	0.91	06B2-33	16	54	30	80	1.37	06B3-33	16	54	40	80	1.89
34	103.23	107.3	06B1-34	14	43	30	65	0.93	06B2-34	16	54	30	80	1.43	06B3-34	16	57	40	85	2.06
35	106.26	110.4	06B1-35	14	43	30	65	0.95	06B2-35	16	54	30	80	1.49	06B3-35	16	57	40	85	2.15
36	109.29	113.4	06B1-36	16	47	30	70	1.06	06B2-36	16	60	30	90	1.70	06B3-36	16	60	40	90	2.32
37	112.32	116.4	06B1-37	16	47	30	70	1.08	06B2-37	16	60	30	90	1.76	06B3-37	16	60	40	90	2.43
38	115.35	119.5	06B1-38	16	47	30	70	1.11	06B2-38	16	60	30	90	1.82	06B3-38	16	60	40	90	2.53
39	118.38	122.5	06B1-39	16	47	30	70	1.13	06B2-39	16	60	30	90	1.88	06B3-39	16	60	40	90	2.64
40	121.41	125.5	06B1-40	16	47	30	70	1.15	06B2-40	16	60	30	90	1.95	06B3-40	16	60	40	90	2.75
42	127.46	131.6	06B1-42	16	53	35	*78	1.56	06B2-42	20	59	50	*88	2.94						
45	136.55	140.7	06B1-45	16	53	35	*78	1.63	06B2-45	20	59	50	*88	3.16	06B3-45	20	59	60	*88	4.18
46	139.58	143.7	06B1-46	16	53	35	*78	1.66												
48	145.64	149.7	06B1-48	16	53	35	*78	1.72	06B2-48	20	59	50	*88	3.39	06B3-48	20	59	60	*88	4.57
50	151.70	155.7	06B1-50	20	53	35	*78	1.74	06B2-50	20	59	50	*88	3.56	06B3-50	20	59	60	*88	4.84
55	166.85	170.8	06B1-55	20	53	35	*78	1.89												
57	172.91	176.9	06B1-57	20	53	35	*78	1.96	06B2-57	20	59	50	*88	4.19	06B3-57	25	59	60	*88	5.81
60	182.00	186.0	06B1-60	20	53	35	*78	2.06	06B2-60	20	59	50	*88	4.49	06B3-60	25	59	60	*88	6.31
76	230.49	234.9	06B1-76	20	53	35	*78	2.71	06B2-76	25	59	50	*88	6.30	06B3-76	25	59	60	*88	9.42
95	288.08	292.5	06B1-95	25	59	40	*88	4.15	06B2-95	25	72	50	*108	9.94	06B3-95	25	80	60	*120	15.47
<b>Cast Iron Wheels</b>																				
38	115.35	119.5	06B1-38C	19	42	32	70	1.40	06B2-38C	19	48	40	80	1.80	06B3-38C	23	54	56	90	2.80
45	136.55	140.7	06B1-45C	19	42	32	70	1.60	06B2-45C	19	48	40	80	2.10	06B3-45C	23	54	56	90	3.20
57	172.91	176.9	06B1-57C	19	42	32	70	1.60	06B2-57C	19	48	40	80	2.50	06B3-57C	23	54	56	90	3.60
76	230.49	234.9	06B1-76C	19	42	32	70	2.10	06B2-76C	19	48	40	80	3.10	06B3-76C	23	60	56	100	4.00
95	288.08	292.5	06B1-95C	19	48	40	80	3.50	06B2-95C	19	54	45	90	4.60	06B3-95C	23	60	56	100	6.50
114	345.68	349.6	06B1-114	19	48	40	80	4.20	06B2-114	19	54	45	95	5.30	06B3-114	23	60	56	100	8.00
150	454.82	459.2	06B1-150	23	54	45	90	9.00	06B2-150	23	60	50	100	10.50	06B3-150	23	75	60	125	14.00

Pinions 8 to 40 teeth in Steel with min. U.T.S. 600N/mm<sup>2</sup>, which can be supplied with induction hardened teeth to 45Rc. Pinions above 40 teeth are in Steel with min 410N/mm<sup>2</sup>  
All Standard Stock Sprockets can be reworked to customers required bore, keyway, and setscrew requirements, on a 48 hour service.

All dimensions in mm.

† Min. toleranced bore which can be machined in sprocket.

\* Sprockets with an asterisk on the hub diameter may be fabricated construction.